



Sidekiq™ VPX400

Antenna-to-Bits, Multi-Channel, Phase Coherent RF Transceiver in a Single MORA-Compliant/SOSA-Aligned 3U VPX Card

A SINGLE WIDEBAND RF CARD WITH MULTI-RECEIVE/MULTI-TRANSMIT CAPABILITIES

COMPLETE SOFTWARE-DEFINED RADIO FOR EW, SIGINT, C5ISR AND OTHER MISSION CRITICAL APPLICATIONS

The MORA-compliant/SOSA-aligned Sidekiq VPX400 is a modular, multi-channel RF transceiver solution that enables rapid development of converged SIGINT/EW platforms while reducing slot count requirements, power consumption, and engineering-related cost. Its modularity complies with MORA 2.4 standards and aligns with the SOSA™ Technical Standard while its core software-defined radio (SDR) technology future-proofs applications by allowing quick adoption of emerging capabilities. Sidekiq VPX400 is also interoperable with Sidekiq VPX410 for access to RF spectrum up to 18 GHz.

KEY HIGHLIGHTS

- Complete RF-to-Bits, Multichannel, Phase Coherent Solution in a Single 3U VPX Card
- Wide RF Tuning Range (Up to 6 GHz)
- Supports 4-Channel Phase Coherent Operation at 200MHz IBW; or 2-Channels Independently Tunable at 450MHz IBW, for a Total of 900MHz IBW for the SDR
- Unified Open API for Use Across All Sidekiq Products
- Typical power consumption Under 40W
- Support for both PCIe and 10/40 GbE

BLOCK DIAGRAM

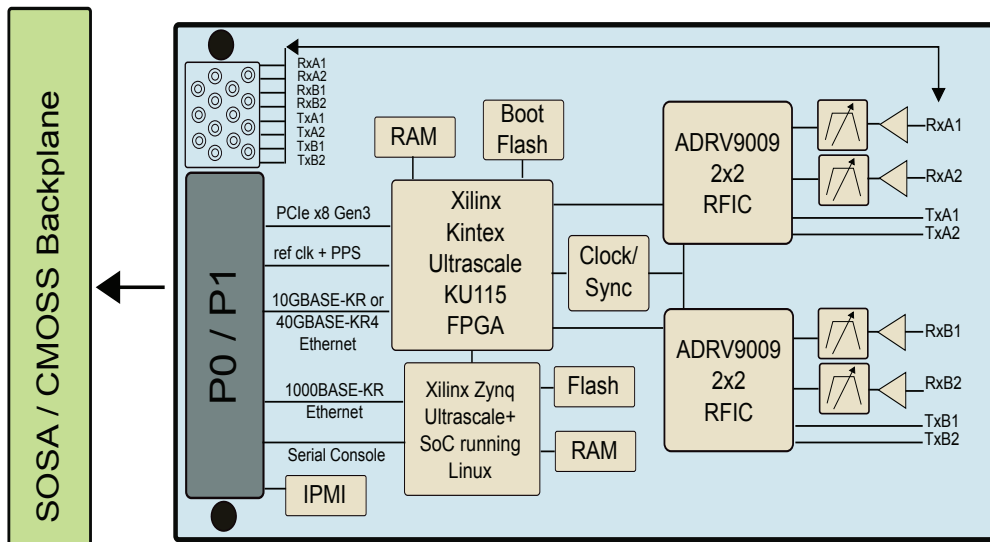

GENERAL SPECIFICATIONS

ENVIRONMENTAL OPTIONS

- ECC1 conduction cooled 0° to 55° C, or
- ECC3 conduction cooled, -40° to 70° C
- Options available for conformal coating and underfill
- Options available for air cooled

PROFILE SPECIFICATION

- SLT3-PAY-1F1U1S1S1U1U2F1H-14.6.11-n
(“-4” for a SOSA aligned option)
- SLT3-PAY-1F1U1S1S1U1U4F1J-14.6.13-n

FORM FACTOR SPECIFICATIONS

DIMENSIONS

- 178.6 mm x 99.8 mm x 23.6 mm
(includes overhang for ejector)

WEIGHT

- 1.1 lbs

DIGITAL SPECIFICATIONS

SYSTEM-ON-CHIP (SOC)

- AMD® Zynq® UltraScale+™ MPSoC XCZU7EV
- 4 GB SSD, with a build option to 32 GB SSD
- 4 GB of DDR4 RAM

FPGA

- AMD Kintex® UltraScale™ XCKU115 FPGA memory
- 5 GB DDR4 Per DDR4 x80 DRAM port(s)
- 256 MB BPI NOR Flash (x16 Async Parallel Flash)

RF TRANSMITTER SPECIFICATIONS

RF TUNING RANGE

- 1 MHz to 6 GHz

NUMBER OF PHASE COHERENT TRANSMITTERS

- Four frequency-phase coherent channels, or
- Two independent pairs of two frequency-phase coherent channels

RF CHANNEL BANDWIDTH

- Up to 200 MHz in 4 channel mode; Up to 450MHz in 2 channel mode

TYPICAL RF OUTPUT POWER

- Up to +5 dBm

MAX D/A SAMPLE RATE

- 500 Msamples/sec

D/A CONVERTER SAMPLE WIDTH

- 14 bits

RF TUNING STEP SIZE

- 5 Hz

RF RECEIVER SPECIFICATIONS

NUMBER OF RECEIVERS

- Four frequency-phase coherent channels, or
- Two independent pairs of two frequency-phase coherent channels

RF TUNING RANGE

- 1 MHz to 6 GHz

RF TUNING STEP SIZE

- < 5 Hz

RF CHANNEL BANDWIDTH

- Up to 200 MHz in 4 channel mode; Up to 450MHz in 2 channel mode

TYPICAL RX NOISE FIGURE

- 8 dB

TYPICAL INPUT IP3 (AT 8 dB NOISE FIGURE)

- +8 dBm

MAX A/D CONVERTER SAMPLE RATE

- 500 Msamples/sec

A/D CONVERTER SAMPLE WIDTH

- 16 bits

RX GAIN MODES

- Manual or automatic (AGC)

PRE-SELECT FILTER

- Seven bandpass RF filters on each RF receiver

Specifications subject to change without notice.

Epiq Solutions is a business dedicated to advancing RF technology through products designed and manufactured in the U.S.A.

Epiq Solutions exports its products strictly in accordance with all US Export Control laws and regulations which shall apply to any purchase or order.

